

SECTION VIEW A-A

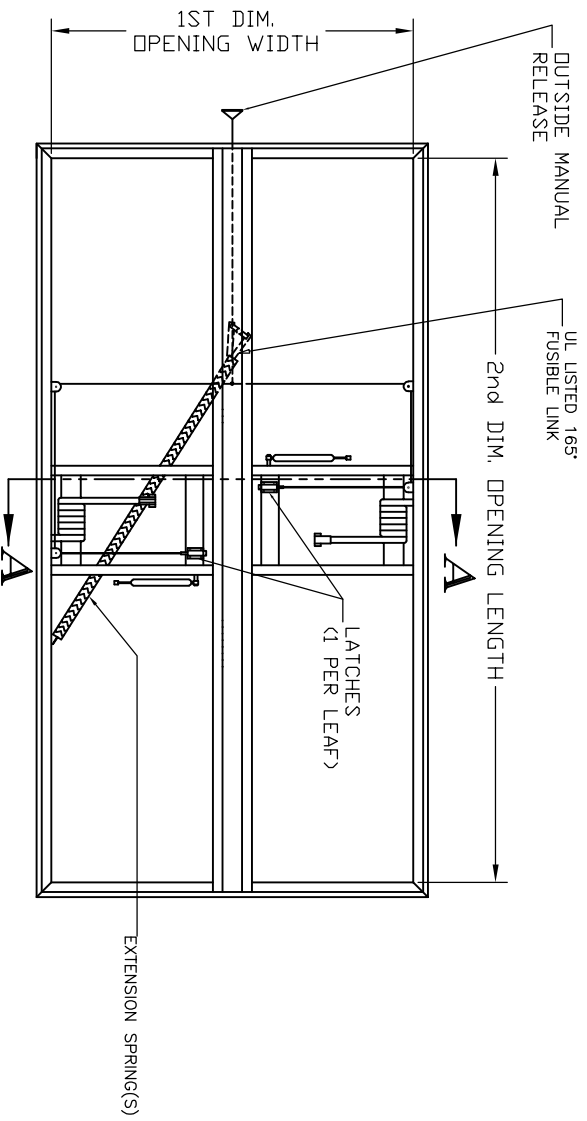
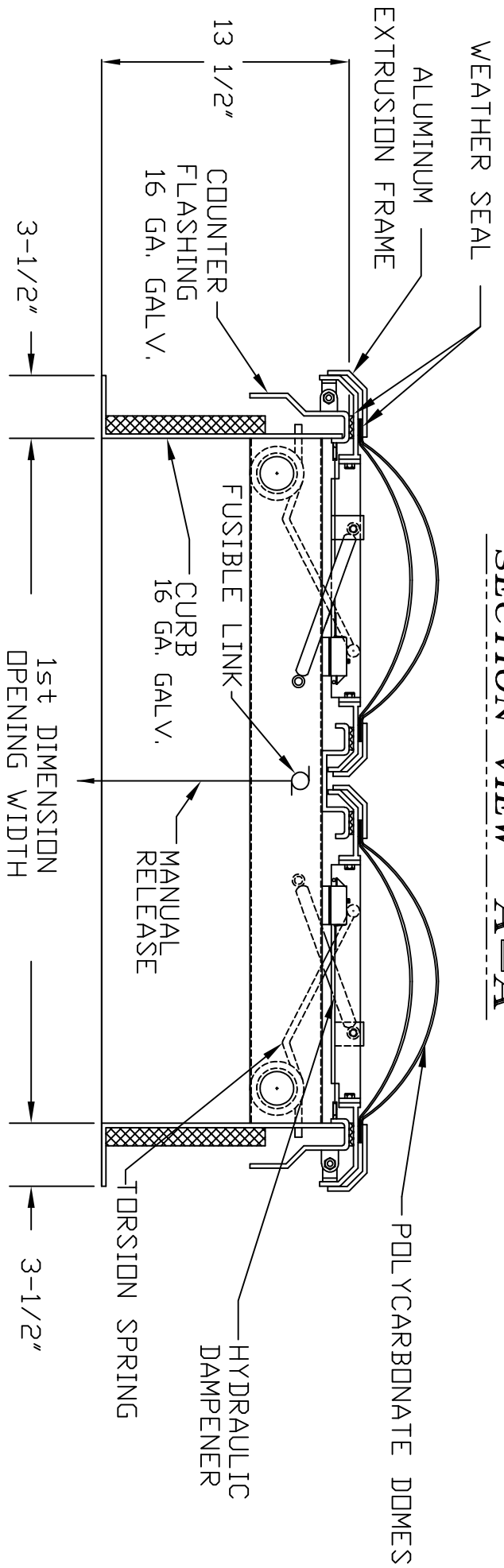

**PLAN VIEW
COVERS REMOVED**

- NOTES:
- * LISTED BY UNDERWRITERS LABORATORIES (UL 793)
 - * RATED TO OPEN AGAINST 10 PSF SNOW/WIND LOAD
 - * RATED TO REMAIN CLOSED AGAINST 30 PSF UPLIFT LOAD
 - * 25 FT OF CABLING PROVIDED FOR INTERIOR RELEASE

ORDER WILL NOT BE RELEASED FOR FABRICATION UNTIL SIGNED COPY IS RECEIVED.

VERIFICATION AND APPROVAL OF GENERAL ARRANGEMENT AND OVERALL DIMENSIONS OF THIS DOCUMENT ARE REQUIRED BEFORE THE ORDER IS ENTERED FOR MANUFACTURING.

APPROVAL SIGNATURE _____

TITLE _____

HELD _____

DATE OF APPROVAL _____

THIS DRAWING IS THE PROPERTY OF COMMERCIAL PRODUCTS GROUP AND CONTAINS PROPRIETARY INFORMATION. NOT TO BE REPRODUCED OR REDISTRIBUTED WITHOUT CPGS' WRITTEN PRIOR CONSENT.

MILCOR®

5030 Corporate Exchange Blvd. SE, Grand Rapids, MI 49512
 PH: 800-624-8642 FAX: 855-549-2674 www.milcorinc.com

UL-SEE DOME SMOKE VENT

DATE	01/29/2020	DRAWN	CD
REV		JOB NO.	
		SHEET 1 of 1	