

ACCESS DOOR

Cam and Hinge Access Doors For Flat Single Wall Ductwork

**DCM
DHG**

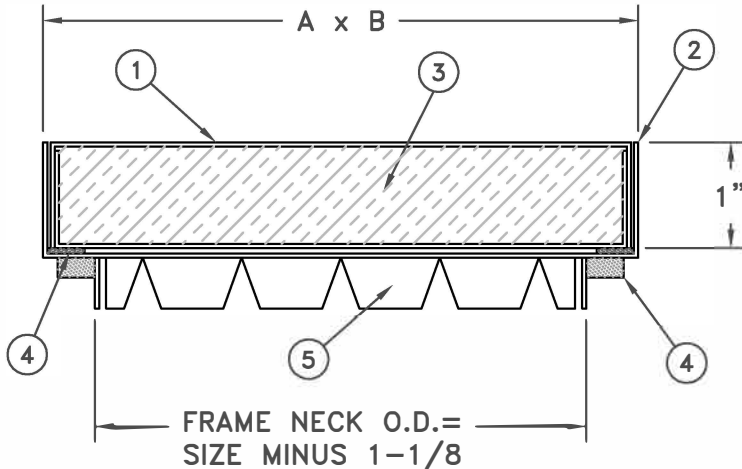

SPECIFICATIONS:

1. Formed 24 gauge metal door
2. Formed 22 gauge metal frame
3. Fiberglass insulation
4. Polyester foam gasket
5. Preformed dovetail tabs

NOTES:

1. Available in galvanized steel. Contact factory for availability of other materials.
2. Available for single wall duct applications.
3. Insulation R-value of 3 (estimate).
4. Tested to 4.5" S.P. with minimal leakage.
5. Reference chart for sizes.

STANDARD SIZES

SIZE	WIDTH A	HEIGHT B	FRAME NECK O.D.	CAMS DCM	CAMS DHG
6x6	6	6	4-7/8 x 4-7/8	2	1
8x8	8	8	6-7/8 x 6-7/8	2	1
10x10	10	10	8-7/8 x 8-7/8	2	1
12x12	12	12	10-7/8 x 10-7/8	2	1
14x14	14	14	12-7/8 x 12-7/8	2	1
16x16	16	16	14-7/8 x 14-7/8	4	2
18x18	18	18	16-7/8 x 16-7/8	4	2
20x20	20	20	18-7/8 x 18-7/8	4	2
24x24	24	24	22-7/8 x 22-7/8	4	2



MODEL DHG
HINGE AND CAM

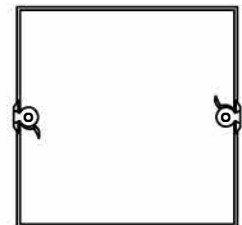

MODEL DCM
DUAL CAMS

JOB NAME: _____
 LOCATION: _____
 ARCHITECT: _____
 ENGINEER: _____
 CONTRACTOR: _____

SUBMITTED BY: _____

MILCOR
BY duravent

4460 44th Street SE, Suite F • Grand Rapids MI 49512
 T (800) 624-86422 • F (855) 549-2674 • www.milcorinc.com