

- NOTES:  
 SIZE: 3'0" X 2'6"  
 1. 70 psf COVER LIVE LOAD RATING  
 2. MILL FINISH ALUMINUM  
 3. ZINC PLATED HARDWARE  
 4. GAS SPRING COVER ASSIST  
 5. R-24 THERMAL RATING  
 6. THERMAL BREAKS FOR INTERIOR THERMAL RESISTANCE

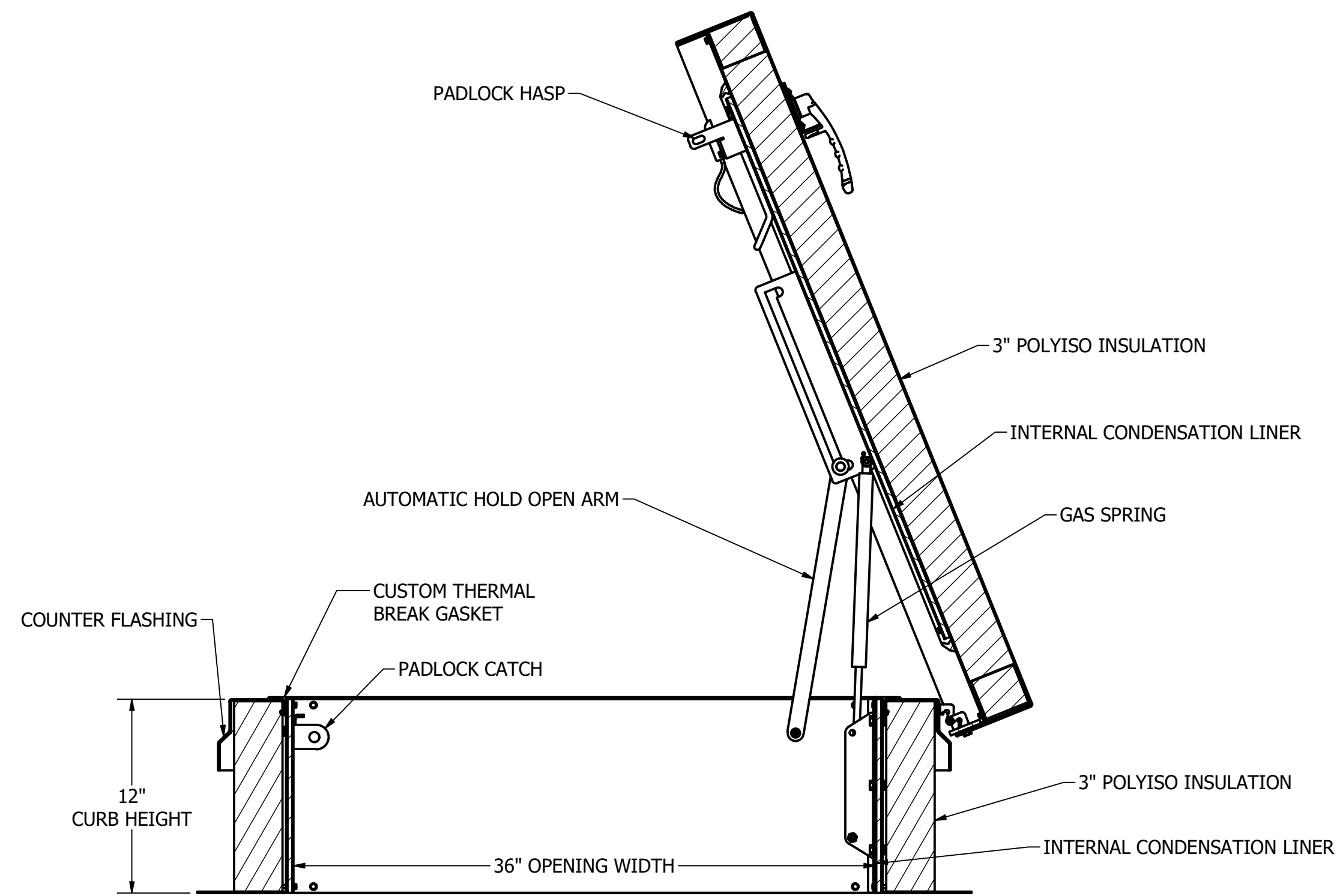
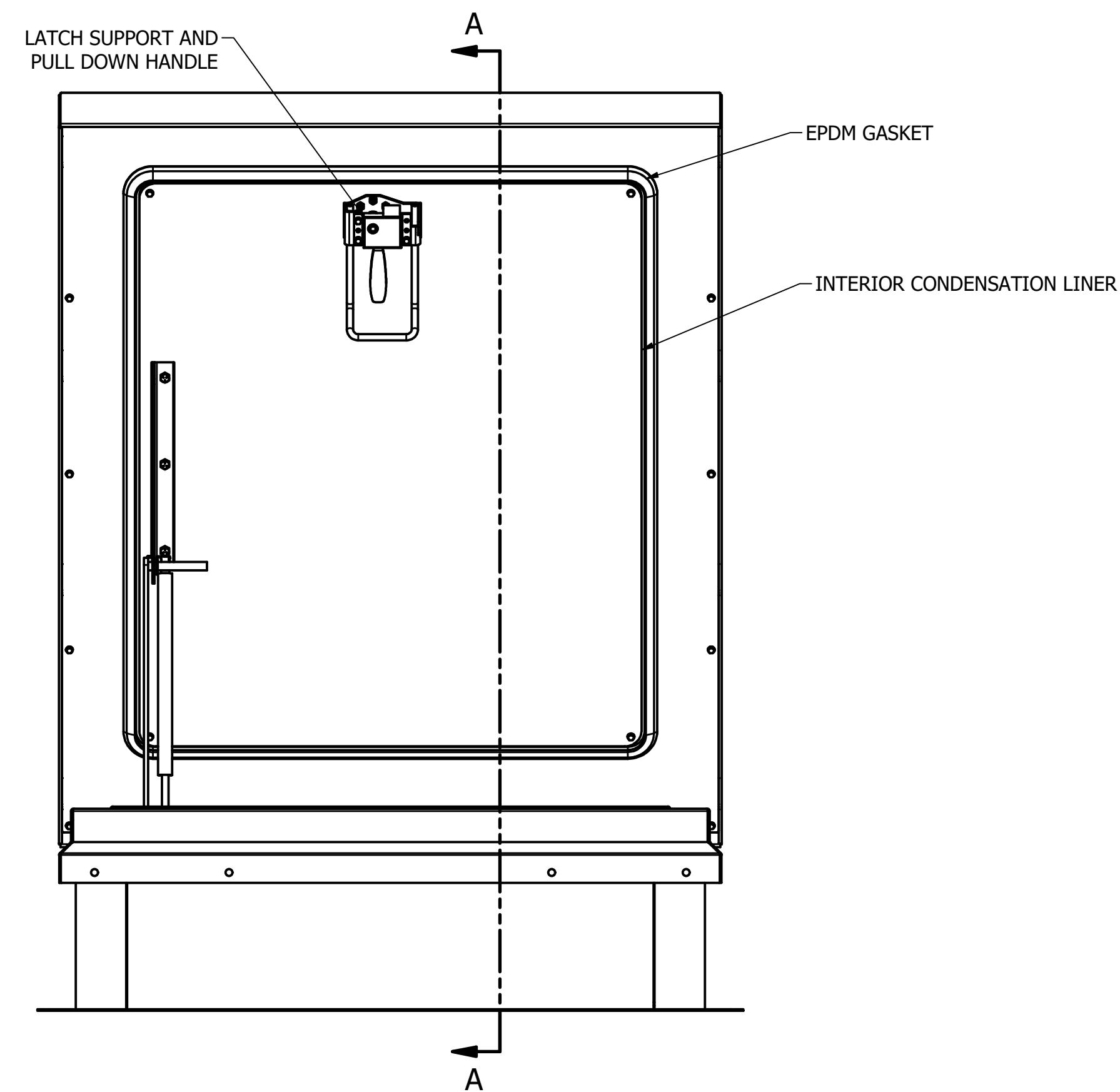
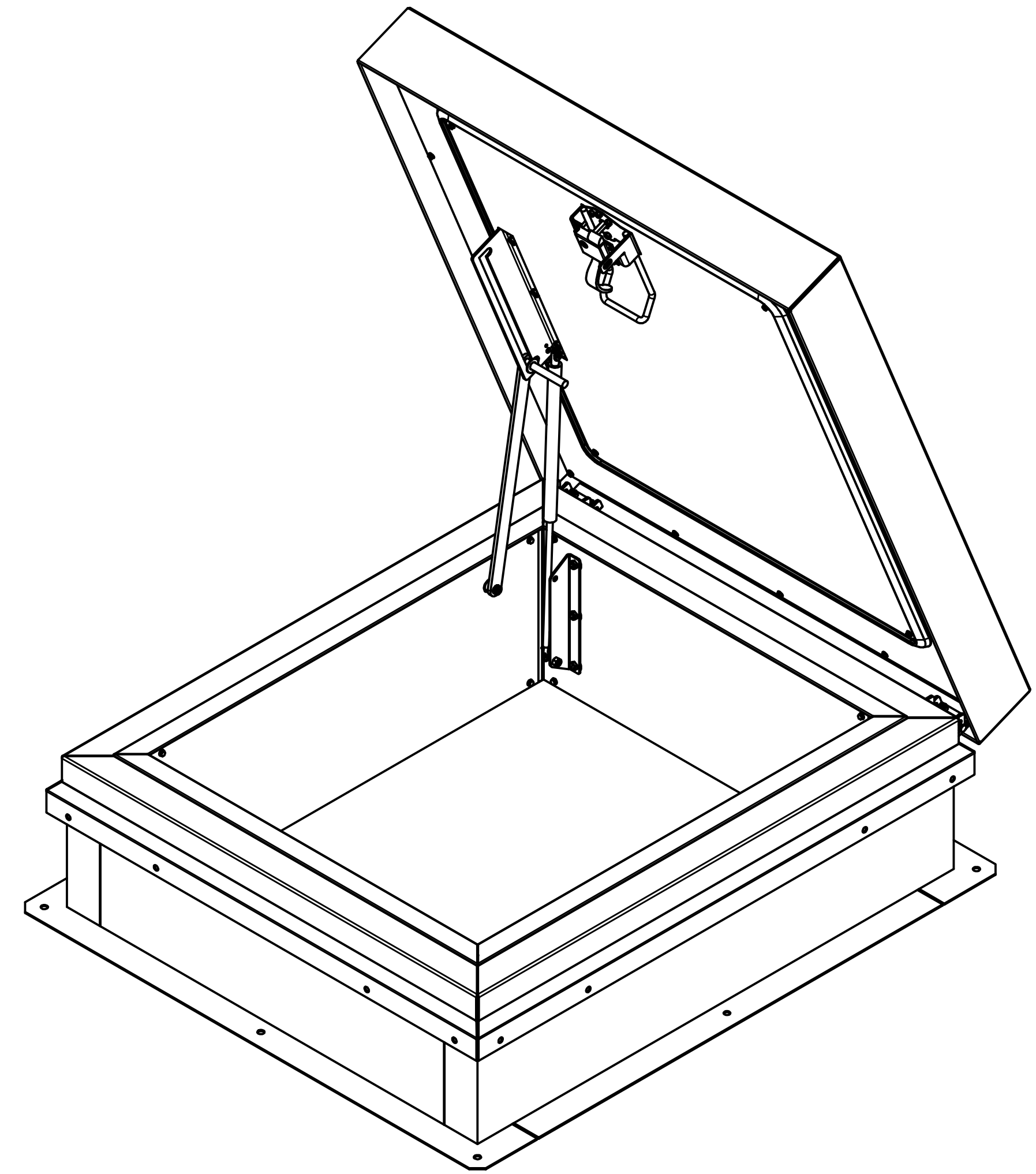

SECTION A-A  
 SCALE 0.14 : 1

ORDER WILL NOT BE RELEASED FOR FABRICATION UNTIL SIGNED COPY IS RECEIVED.

VERIFICATION AND APPROVAL OF GENERAL ARRANGEMENT AND OVERALL DIMENSIONS FOR THIS DOCUMENT ARE REQUIRED BEFORE THE ORDER IS ENTERED FOR MANUFACTURING.

APPROVAL SIGNATURE \_\_\_\_\_

TITLE HELD \_\_\_\_\_

DATE OF APPROVAL \_\_\_\_\_

DRAWN juriaran	7/23/2020	DURAVENT GROUP Fax: 855-549-2674 www.duraventgroup.com 28 W.Adams, Suite 1810 Detroit, MI 48226 Ph: 800-624-8642	
CHECKED	<b>MILCOR</b> by duravent	TITLE THERMAL PRO ROOF HATCH - 36X30 3501-241-9	
QA	TOLERANCE UNLESS SPECIFIED	SIZE D	REV A
MFG	.XXX ± 0.005"	DWG NO 3501-241-9 SUBMITTAL	
APPROVED	.XX ± 0.01"	SCALE	
	FRACT. ± 1/16"		
	ANGLES ± 1'		