

STANDARD RETROFIT SAFETY RAILING COMPATIBILITY:

(NOMINAL CURB CAP WIDTH X LENGTH)
 30.5" x 48" - MINIMUM
 52" x 70" - MAXIMUM

RAIL HEIGHT MEETS 42" REQUIREMENT

DISPLAYED DIMENSION ARE OUTSIDE DIMENSIONS OF CURB, NOT NOMINAL.

FEATURES:

1. SELF CLOSING HINGES
2. POWER COATED SAFETY YELLOW
3. SLOTTED CORNER BRACKET HOLES FOR UNIVERSAL COMPATABILITY AND EASE OF INSTALLATION
4. RAIL AND GATE TELESCOPE TO ACCOMODATE MULTIPLE HATCH SIZES.

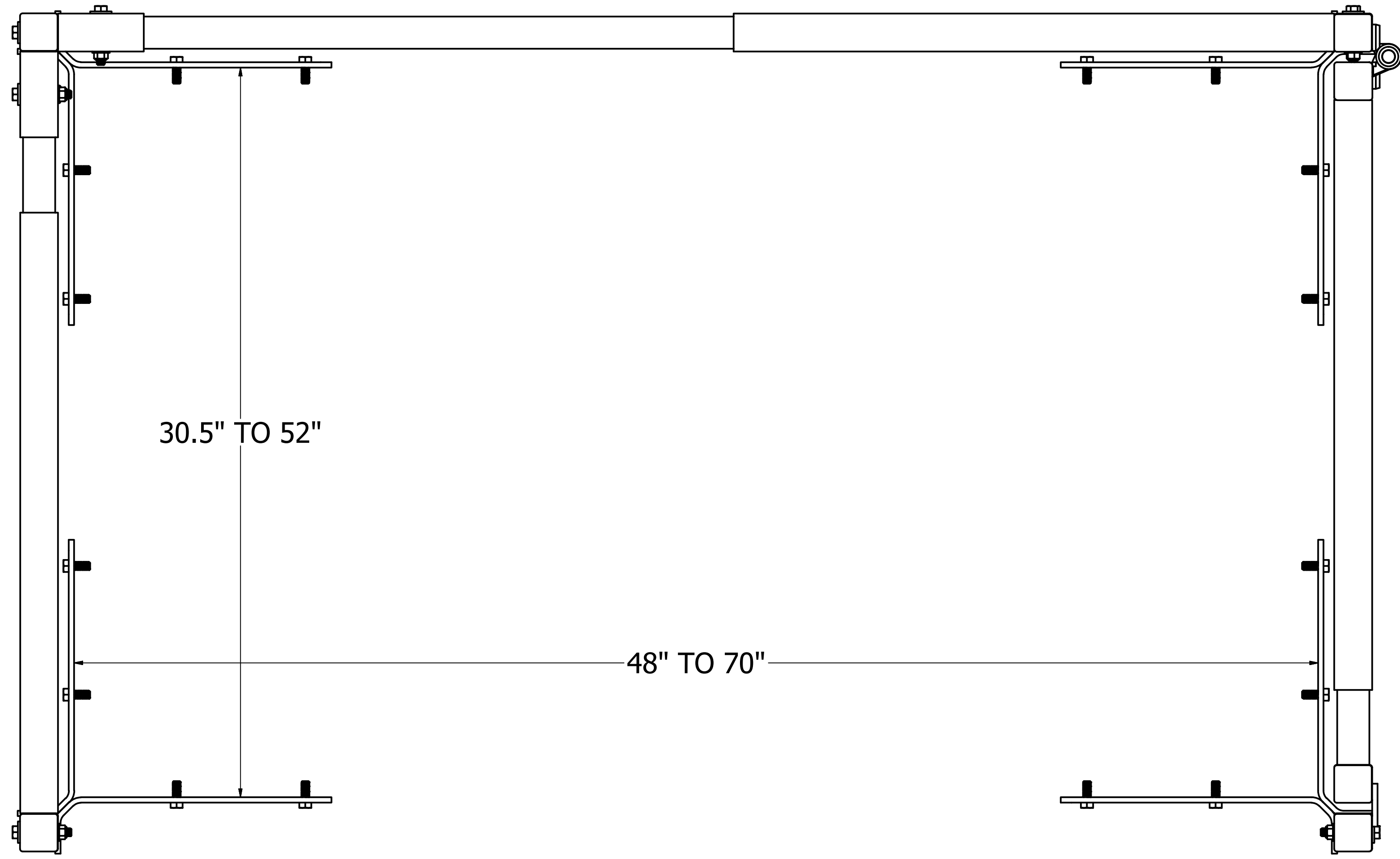

ORDER WILL NOT BE RELEASED FOR FABRICATION UNTIL SIGNED COPY IS RECEIVED

VERIFICATION AND APPROVAL OF GENERAL ARRANGEMENT AND OVERALL DIMENSIONS FOR THIS DOCUMENT ARE REQUIRED BEFORE THE ORDER IS ENTERED FOR MANUFACTURING.

APPROVAL SIGNATURE _____

TITLE HELD _____

DATE OF APPROVAL _____

DRAWN juriaran	5/15/2020	HART & COOLEY INC. Fax: 855-549-2674 www.hartandcooleyinc.com	
CHECKED		5030 Corporate Exchange Blvd. SE Grand Rapids, MI. 49512 Ph: 800-624-8642	
QA	TOLERANCE UNLESS SPECIFIED	TITLE	
MFG	.XXX ± 0.005"	RETROFIT SAFETY RAIL, MID	
APPROVED	.XX ± 0.01"	SIZE	DWG NO
	FRACT. ± 1/16"	D	MSTR-48-70_SUB
	ANGLES ± 1'	SCALE	REV A
			SHEET 1 OF 1