

8 7 6 5 4 3 2 1

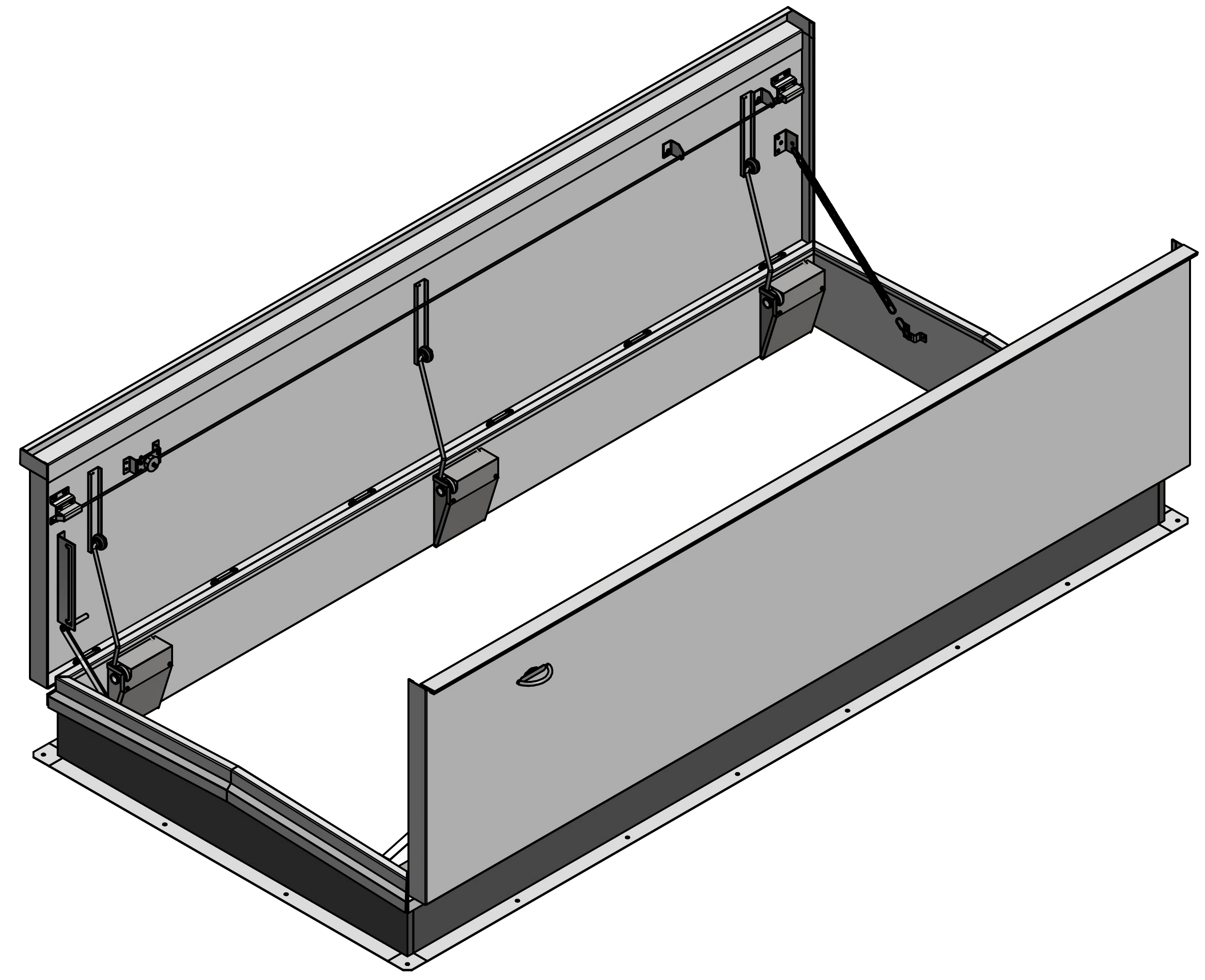

NOTES:
SIZE: RB-5'0"X11'0"
 1) 40psf COVER LIVE LOAD RATING
 2) HATCH PAINTED WHITE
 3) MATERIALS:
 14ga GALVANIZED, COVER
 14ga GALVANIZED, CURB
 14ga GALVANIZED, COUNTER FLASHING
 22ga GALVANIZED, COVER LINER

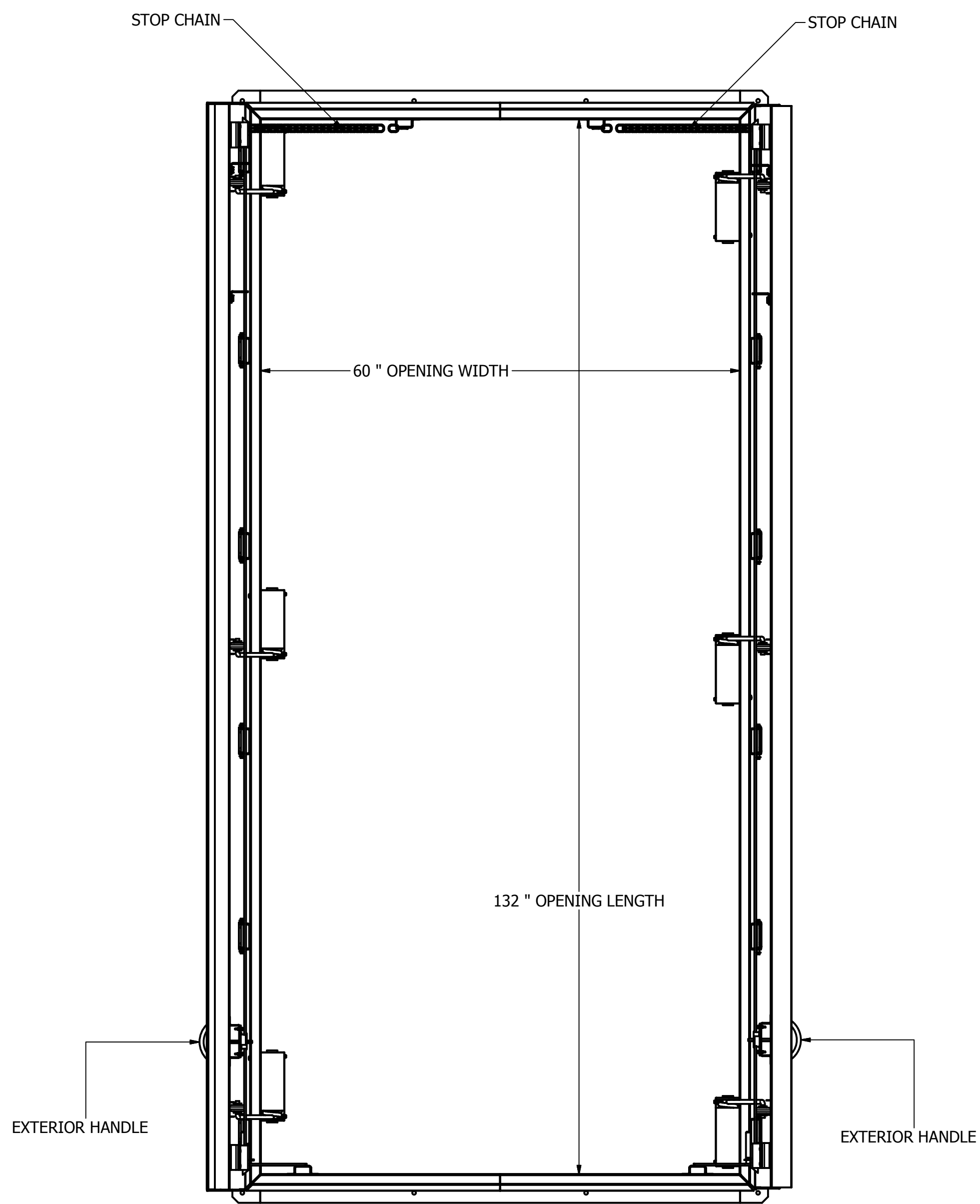
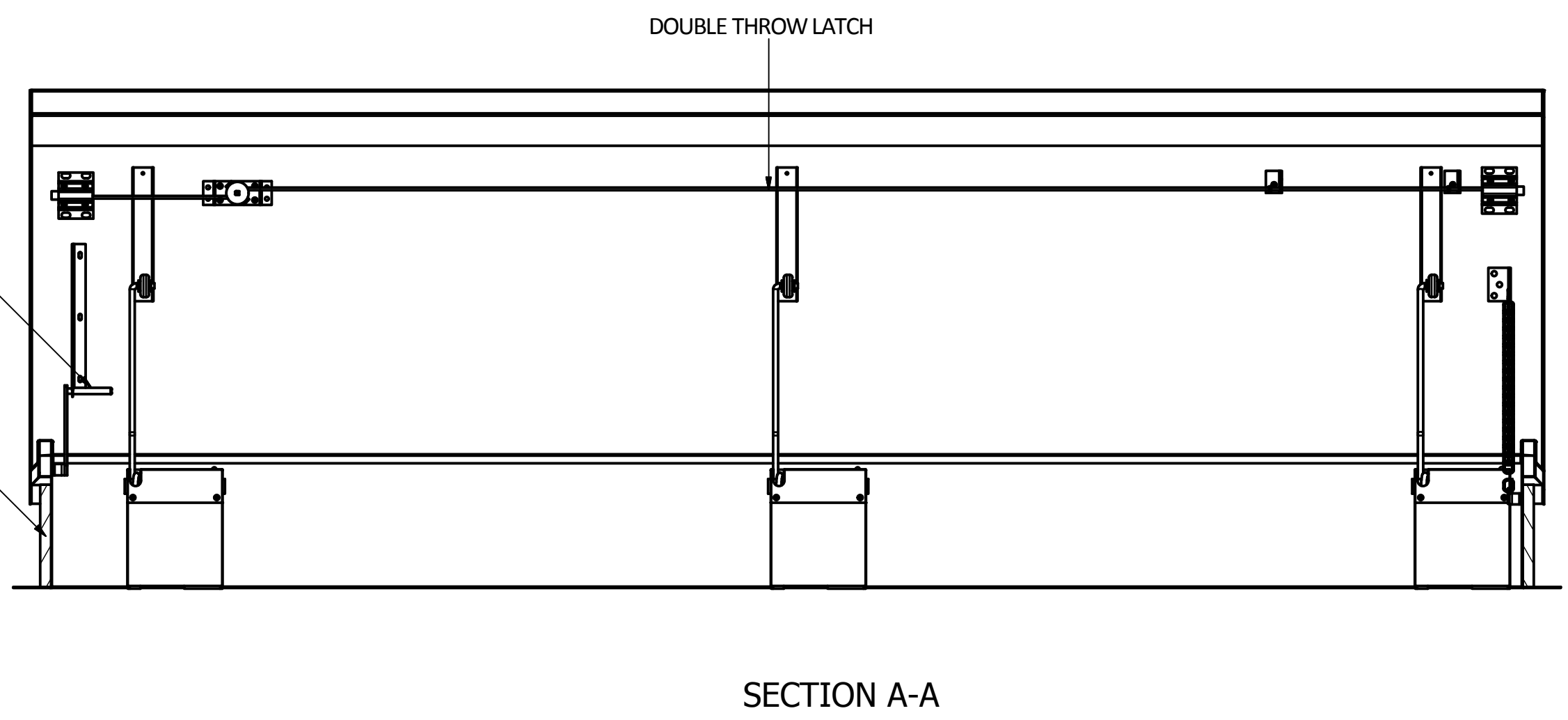
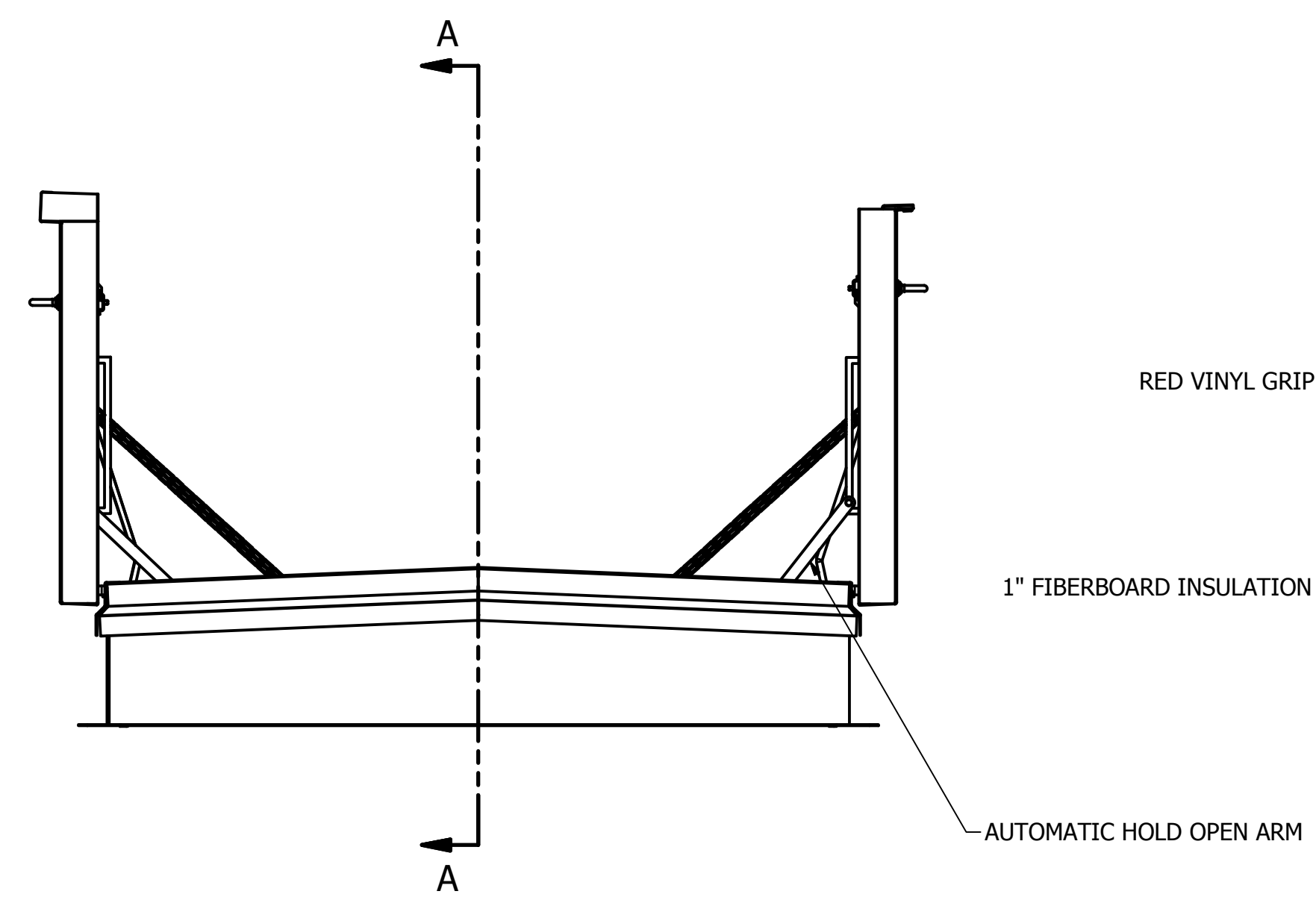

ORDER WILL NOT BE RELEASED FOR FABRICATION UNTIL SIGNED COPY IS RECEIVED.

VERIFICATION AND APPROVAL OF GENERAL ARRANGEMENT AND OVERALL DIMENSIONS FOR THIS DOCUMENT ARE REQUIRED BEFORE THE ORDER IS ENTERED FOR MANUFACTURING.

APPROVAL SIGNATURE _____

TITLE HELD _____

DATE OF APPROVAL _____

DRAWN	CMD	2/25/2015	Hart & Cooley Inc. Fax: 855-549-2674 www.hartandcooleyinc.com		
CHECKED	MILCOR		5030 Corporate Exchange Blvd. SE Grand Rapids, MI. 49512 Ph: 800-624-8642		
QA	TOLERANCE UNLESS SPECIFIED		TITLE		
MFG	.XXX ± 0.005"		RB-4 DOUBLE LEAF ROOF ASSEMBLY		
APPROVED	.XX ± 0.01"		SIZE	DWG NO	REV
	FRACT. ± 1/16"		D	3501-212-9	--
	ANGLES ± 1'		SCALE	SHEET 1 OF 1	

8 7 6 5 4 3 2 1